



United Technologies

PRODUCT SELECTION DATA

AIR-COOLED LIQUID CHILLERS, REVERSIBLE AIR-TO-WATER HEAT PUMPS



Commercial and industrial applications

Compact design

Quiet operation

Variable water flow

Partial heat reclaim

30RBS 039-160 C
30RQS 039-160 B

AQUASNAP

Nominal cooling capacity 30RBS: 40-156 kW
Nominal cooling capacity 30RQS: 38-148 kW
Nominal heating capacity 30RQS: 42-150 kW

The Aquasnap range of liquid chillers/air-to-water heat pumps was designed for commercial (air conditioning of offices, hotels etc.) or industrial (low-temperature process units etc.) applications.

The Aquasnap integrates the latest technological innovations:

- Ozone-friendly refrigerant R410A
- All-aluminium microchannel heat exchangers for the cooling only units (30RBS)
- Scroll compressors
- Low-noise fans made of a composite material
- Auto-adaptive microprocessor control
- Electronic expansion valve
- Variable-speed pump (option)

The Aquasnap can be equipped with a hydraulic module integrated into the unit chassis, limiting the installation to straightforward operations like connection of the power supply and the chilled water supply and return piping.



CARRIER participates in the ECP programme for LCP/HP
Check ongoing validity of certificate:
www.eurovent-certification.com

FEATURES

Quiet operation

- Compressors
 - Low-noise scroll compressors with low vibration level
 - The compressor assembly is installed on an independent chassis and supported by anti-vibration mountings
 - Dynamic suction and discharge piping support, minimising vibration transmission (Carrier patent).
- Condenser (30RBS)/air evaporator/condenser (30RQS) section
 - Vertical condenser coils
 - Anti-vibration mountings and optional grilles to protect the heat exchanger against possible shocks.
 - Low-noise latest-generation Flying Bird IV fans, made of a composite material (Carrier patent) are now even quieter and do not generate intrusive low-frequency noise
 - Rigid fan installation for reduced start-up noise (Carrier patent).

Easy and fast installation

- Integrated hydraulic module (option)
 - Centrifugal low or high-pressure water pump (as required), based on the pressure loss of the hydraulic installation

Hydraulic module



- Single or dual water pump (as required) with operating time balancing and automatic changeover to the back-up pump if a fault develops
- Water filter protects the pump against circulating debris
- Pressure measurement, using two pressure transducers and allowing indication of water flow rate, water pressure and lack of water.
- High-capacity membrane expansion tank ensures pressurisation of the water circuit
- Overpressure valve, set to 4 bar
- Speed variator on the pumps (option) to ensure the correct flow rate, based on the system requirements
- Thermal insulation and frost protection down to -20°C, using an electric resistance heater (see table of options)
- Physical features
 - The unit has a small footprint and a low height (1330 mm) allowing it to blend in with any architectural styles.
 - The unit is enclosed by easily removable panels, covering all components (except air heat exchangers and fans).
- Simplified electrical connections
 - A single power supply point without neutral
 - Main disconnect switch (option 70) with high trip capacity
 - Transformer for safe 24 V control circuit supply included

- Fast commissioning
 - Systematic factory operation test before shipment
 - Quick-test function for step-by-step verification of the instruments, electrical components and motors.

Economical operation

- Optional variable-speed pump for economical operation
- The control algorithm adjusts the water flow rate based on the actual system requirements and obsoletes the need for the control valve at the unit outlet.
- Increased energy efficiency at part load
 - The refrigerant circuit includes several compressors connected in parallel. At part load, around 99% of the operating time, only the compressors that are absolutely necessary operate. At these conditions the compressors operating are more energy efficient, as they use the total condenser and evaporator capacity.
 - The electronic expansion device (EXV) allows operation at a lower condensing pressure (SEER and SCOP Seasonal performances optimisation).
 - Dynamic superheat management for better utilisation of the water heat exchanger surface.
 - Defrost cycle optimisation (30RQS).
- Reduced maintenance costs
 - Maintenance-free scroll compressors
 - Fast diagnosis of possible incidents and their history via the Touch Pilot Junior control
 - R410A refrigerant is easier to use than other refrigerant blends.

Environmental care

- Ozone-friendly R410A refrigerant
 - Chlorine-free refrigerant of the HFC group with zero ozone depletion potential
 - Very efficient - gives an increased energy efficiency ratio
 - 50% reduction in the refrigerant charge through the use of micro-channel heat exchangers for the cooling only units (30RBS)
- Leak-tight refrigerant circuit
 - Brazed refrigerant connections for increased leak-tightness
 - Reduction of leaks due to reduced vibration levels and elimination of capillary tubes (TXVs)
 - Verification of pressure transducers and temperature sensors without transferring refrigerant charge.

Partial view of the hydraulic circuit



FEATURES

Superior reliability

- State-of-the-art concept
 - Cooperation with specialist laboratories and use of limit simulation tools (finite element calculations) for the design of the critical components, e.g. motor supports, suction/discharge piping etc.
 - All aluminium micro-channel heat exchanger (MCHE) on cooling only units (30RBS), offers increased corrosion resistance compared to traditional coils. The all-aluminium design eliminates the formation of galvanic currents between aluminium and copper that cause coil corrosion.
- Auto-adaptive control
 - Control algorithm prevents excessive compressor cycling and permits reduction of the water quantity in the hydraulic circuit (Carrier patent)
 - Hydraulic module with integrated pressure transducers allowing measurement of the water pressure at two points, as well as measurement of the water flow rate and detection of lack of water and pressure. This considerably reduces the risk of problems such as frost accumulation on the water heat exchanger.
 - Automatic compressor unloading in case of abnormally high condensing pressure. If an anomaly occurs (e.g. fouled air heat exchanger coil, fan failure) Aquasnap continues to operate, but at reduced capacity.
 - On Heat pump version 30RQS specific Free Defrost algorithm to optimise performance and comfort even during defrost period.
- Exceptional endurance tests
 - Corrosion resistance tests in salt mist in the laboratory
 - Accelerated ageing test on components that are submitted to continuous operation: compressor piping, fan supports
 - Transport simulation test in the laboratory on a vibrating table.

Touch Pilot Junior control

The Touch Pilot Junior features a control with advanced communication technology over Ethernet (IP), user-friendly and intuitive user interface with 4.3" colour touch screen.

- Energy management
 - Internal time schedule clock: Controls heat pump on/off times and operation at a second set-point
 - Set-point offset based on the outside air temperature
 - Master/slave control of two heat pumps operating in parallel with operating time equalisation and automatic change-over in case of a unit fault.
- Integrated advanced communication features
 - Night mode: Capacity and fan speed limitation for reduced noise level
 - With hydraulic module: Water pressure display and water flow rate calculation
 - Easy and high-speed communication technology over Ethernet (IP) to a building management system
 - Access to multiple unit parameters.
 - Without hydraulic module: 0-10V output is available for external variable speed pump control

- 4.3" Touch Pilot Junior user interface

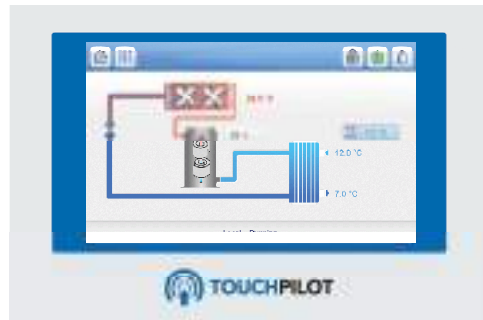

- Intuitive and user-friendly 4.3 inch touch screen interface
- Concise and clear information is available in local languages
- Complete menu, customised for different users (end user, service personnel or Carrier engineers).

Remote management (standard)

Units with Touch Pilot Junior control can be easily accessed from the internet, using a PC with an Ethernet connection. This makes remote control quick and easy and offers significant advantages for service operations.

The Aquasnap is equipped with an RS485 serial port that offers multiple remote control, monitoring and diagnostic possibilities. Carrier offers a vast choice of control products, specially designed to control, manage and supervise the operation of an air conditioning system. Please consult your Carrier representative for more information.

The Aquasnap also communicates with other building management systems via optional communication gateways.

A connection terminal allows remote control of the Aquasnap by wired cable:

- Start/stop: Opening of this contact will shut down the unit
- Dual set-point: Closing of this contact activates a second set-point (example: unoccupied mode).
- Demand limit: Closing of this contact limits the maximum heat pump capacity to a predefined value.
- Operation indication: This volt-free contact indicates that the heat pump is operating (cooling load).
- Alarm indication: This volt-free contact indicates the presence of a major fault that has led to the shut-down of one or several refrigerant circuits.

Flying Bird IV fan

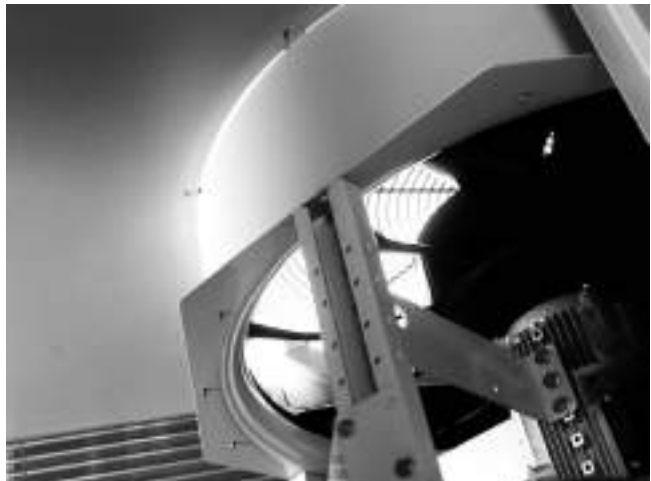

FEATURES

All-aluminium micro-channel heat exchanger (MCHE)



Already utilised in the automobile and aeronautical industries for many years, the MCHE micro-channel heat exchanger is entirely made of aluminium. This one-piece concept significantly increases its corrosion resistance by eliminating the galvanic currents that are created when two different metals (copper and aluminium) come into contact in traditional heat exchangers.

As an option, the Enviro-Shield and Super Enviro-Shield anti-corrosion protections have been developed to increase the application range of the MCHE coil from medium to very corrosive environments. With Enviro-Shield protection, corrosion resistance of the MCHE coil is doubled without any impact on heat exchange.

With Super Enviro-Shield protection corrosion resistance of the MCHE coil is multiplied by four, and allows use in very corrosive industrial or marine environments

The MCHE heat exchanger allows a reduction in chiller refrigerant charge by up to 50%.

The low thickness of the MCHE reduces air pressure losses by 50% and makes it less susceptible to fouling (e.g. by sand) than a traditional coil. Cleaning of the MCHE heat exchanger is very fast using a dry air jet or a high-pressure washer, while observing the usage precautions.

HYDRAULIC MODULE (OPTION 116)

This module is equipped with pressure transducers to optimise unit operation at the hydraulic level.

The hydraulic module option reduces the installation time. The unit is factory-equipped with the main hydraulic components required for the system: screen filter, water pump, expansion tank, relief valve and water pressure transducers.

The pressure transducers allow the Touch Pilot Junior control to:

- Display the available pressure at the unit outlet and the static system pressure
- Calculate the instantaneous flow rate, using an algorithm that integrates the unit characteristics
- Integrate the system and water pump protection devices (lack of water, water pressure, water flow rate etc.)

Several water pump types are available: primary single or dual low-pressure pump (RQS only), single or dual high-pressure pump.

An automatic pump start-up algorithm protects the heat exchanger and the hydraulic module piping against frost down to -10°C (30RBS)/ 0°C (30RQS) outside temperature, if the water heat exchanger frost protection option is installed. If necessary increased frost protection down to -20°C is possible by adding heaters to the hydraulic module piping (see option 42).

The hydraulic module option is integrated into the unit without increasing its dimensions and saves the space normally used for the water pump.

Typical hydraulic circuit diagram

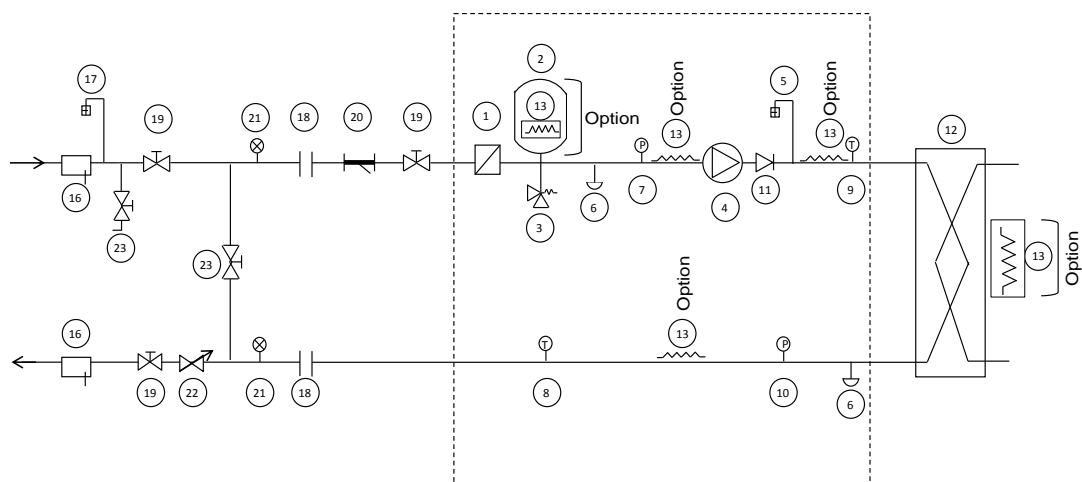

Legend

Components of the unit and hydraulic module

- 1 Screen filter (Mesh 1.2 mm)
- 2 Expansion tank (option)
- 3 Discharge valve
- 4 Available pressure pump (single pump, or dual pump)
- 5 Air purge
- 6 Water drain valve
- 7 Pressure sensor
Note: Gives pump suction pressure information (see regulation manual)
- 8 Temperature probe
Note: Gives heat exchanger leaving temperature information (see regulation manual)
- 9 Temperature probe
Note: Gives heat exchanger entering temperature information (see regulation manual)
- 10 Pressure sensor
Note: Gives heat exchanger leaving pressure information (see regulation manual)
- 11 Check valve (If dual pump)
- 12 Plate heat exchanger
- 13 Heater or tracer for frost protection (Option)
- 14 Flow sensor for water heat exchange

Installation components

- 16 Thermowell
- 17 Air purge
- 18 Flexible connexion
- 19 Shut-off valve
- 20 Screen filter (obligatory for a unit without hydraulic module)
- 21 Pressure gauge
- 22 Water flow control valve
Note: Not necessary for a hydraulic module with a variable-speed pump
- 23 Charge valve
- 24 Frost protection bypass valve (when shut-off valves (19) are closed during winter)
- 25 Buffer tank (if necessary)

--- Hydraulic module (unit with hydraulic module)

Notes:

- The system must be protected against frost.
- The hydraulic module of the unit and the exchanger can be protected (option factory installed) against frost with electric heaters and tracers (13).
- The pressure sensors are installed at connections without Schraeder valves. Depressurise and drain the system before any intervention.

Electrical data, units with hydraulic modules

The pumps that are factory-installed in these units comply with the European Ecodesign directive ErP. The additional electrical data required by regulation 640/2009 is given in the installation, operation and maintenance manual.

This regulation concerns the application of directive 2009/125/EC on the eco-design requirements for electric motors.

VARIABLE WATER FLOW SYSTEM (VWF)

Variable water flow is a hydraulic control function package that permits control of the water flow rate.

The VWF not only ensures control at full load, a specific Carrier algorithm linked to an electronic frequency converter also continuously modulates the flow rate to minimise pump consumption at full load as well as part load.

The hydraulic module includes pressure transducers that permit intelligent measurement of the water flow rate and real-time display on the Touch Pilot Junior interface. All adjustments can be made directly on the interface, speeding up start-up and maintenance.

As VWF acts directly on the pump, the system no longer requires the control valve at the unit outlet. However, for applications with two-way valves a bypass system must be kept to guarantee the minimum flow rate.

Operating logic

■ Full-load set point

The flow rate control at full load uses the Touch Pilot Junior interface, reducing the pump speed. This first control saves energy that would normally be dissipated in the control valve. For example, if the pressure supplied by the pump is reduced by 20% the power consumption of the pump is reduced by the same ratio, compared to a traditional installation.

■ Operating mode at part load

Touch Pilot Junior control includes two part-load operating modes:

- Constant outlet pressure control
- Constant delta T control.

1 – Constant unit outlet pressure control

The control continuously acts on the pump speed to ensure a constant outlet pressure.

This solution is suitable for installations with two-way valves. When these close, the water speed will accelerate in the system branches that are still open. For a fixed-speed pump this results in an unnecessary increase of the pressure at the pump outlet.

The outlet pressure control mode ensures that each circuit branch always has a uniform supply, without unnecessary energy waste.

In industrial processes such as plastic injection moulding, this solution ensures that each terminal unit has the correct pressure supply.

2 – Constant delta T control

The VWF algorithm maintains a constant delta T no matter what the unit load, reducing the flow rate to the minimum.

This solution can be used for systems with two-way or three-way valves and achieves higher energy savings than the “Constant unit outlet pressure control” mode. It is suitable for the majority of comfort applications.

PHYSICAL DATA, 30RBS

30RBS		039	045	050	060	070	080	090	100	120	140	160		
Cooling														
Standard unit Full load performances*	CA1	Nominal capacity	kW	40	44	51	58	67	79	87	97	114	135	156
		EER	kW/kW	2,87	2,76	2,67	2,66	2,72	2,70	2,73	2,73	2,67	2,70	2,65
	Eurovent class			C	C	D	D	C	C	C	C	D	C	D
	CA2	Nominal capacity	kW	53	59	69	81	85	98	114	126	151	171	194
EER		kW/kW	3,44	3,32	3,12	3,31	2,97	3,06	3,18	3,09	3,10	2,99	3,01	
Standard unit Seasonal energy efficiency**	SEER_{12/7°C} Comfort low temp.		kWh/kWh	3,86	3,97	4,03	3,92	3,79	3,85	4,16	4,16	4,07	3,93	4,17
	η_s cool_{12/7°C}		%	152	156	158	154	149	151	164	163	160	154	164
	SEPR_{12/7°C} Process high temp.		kWh/kWh	5,27	5,31	5,26	5,09	4,92	5,16	4,95	5,12	5,51	4,90	5,32
Unit with option 6B Seasonal energy efficiency**	SEPR_{-2/-8°C} Process medium temp.		kWh/kWh	2,88	3,21	2,91	3,09	3,04	2,75	2,97	3,12	3,10	3,07	3,02
Integrated Part Load Value	IPLV.SI	kW/kW	4,540	4,710	4,810	4,580	4,260	4,390	4,550	4,530	4,550	4,290	4,640	
Sound levels														
Standard unit														
Sound power level ⁽¹⁾		dB(A)	80	81	81	81	87	87	84	84	84	84	90	90
Sound pressure level at 10 m ⁽²⁾		dB(A)	49	49	49	49	55	55	52	52	52	52	58	58
Unit with option 15LS														
Sound power level ⁽¹⁾		dB(A)	79	80	80	80	80	80	83	83	83	83	83	83
Sound pressure level at 10 m ⁽²⁾		dB(A)	48	48	48	48	48	48	51	51	51	51	51	51
Dimensions														
Length	mm	1061	1061	1061	1061	1061	1061	2258	2258	2258	2258	2258	2258	
Width	mm	2050	2050	2050	2050	2050	2050	2050	2050	2050	2050	2050	2050	
Height	mm	1330	1330	1330	1330	1330	1330	1330	1330	1330	1330	1330	1330	
Operating weight with MCHE coil⁽³⁾														
Standard unit without hydraulic module		kg	429	436	442	454	454	471	766	776	789	896	928	
Standard unit with hydraulic module														
Single high-pressure pump		kg	459	466	472	484	484	501	798	808	825	935	967	
Dual high-pressure pump		kg	484	492	497	510	510	527	843	853	873	972	1004	
Compressors														
Hermetic scroll compressors, 48.3 r/s														
Circuit A			2	2	2	2	2	2	3	3	3	2	2	
Circuit B			-	-	-	-	-	-	-	-	-	2	2	
No of control stages			2	2	2	2	2	2	3	3	3	4	4	
Refrigerant charge with MCHE coil⁽³⁾														
R-410A														
Circuit A		kg	4.7	5.3	5.9	6.7	6.2	7.3	10.7	10.8	11.4	6.5	7.4	
		teqCO ₂	9.8	11.1	12.3	14.0	12.9	15.2	22.3	22.6	23.8	13.6	15.5	
Circuit B		kg	-	-	-	-	-	-	-	-	-	6.5	7.4	
		teqCO ₂	-	-	-	-	-	-	-	-	-	13.6	15.5	

- * In accordance with standard EN14511-3:2013
 ** In accordance with standard EN14825:2016, average climate
 CA1 Cooling mode conditions: Evaporator water entering/leaving temperature 12°C/7°C, outside air temperature 35°C, evaporator fooling factor 0 m².K/W
 CA2 Cooling mode conditions: Evaporator water entering/leaving temperature 23°C/18°C, outside air temperature 35°C, evaporator fooling factor 0 m².K/W
 η_s cool_{12/7°C} & SEER_{12/7°C} **Bold values compliant to Ecodesign regulation: (EU) No 2016/2281 for Comfort application**
 SEPR_{12/7°C} **Bold values compliant to Ecodesign regulation: (EU) No 2016/2281 for Process application**
 SEPR_{-2/-8°C} **Bold values compliant to Ecodesign regulation: (EU) No 2015/1095 for Process application**
 IPLV.SI Calculations according to standard performances AHRI 551-591 (SI).
 (1) In dB ref=10⁻¹² W, (A) weighting. Declared dualnumber noise emission values in accordance with ISO 4871 (with an associated uncertainty of +/-3dB(A)). Measured in accordance with ISO 9614-1 and certified by Eurovent.
 (2) In dB ref 20μPa, (A) weighting. Declared dualnumber noise emission values in accordance with ISO 4871 (with an associated uncertainty of +/-3dB(A)). For information, calculated from the sound power level Lw(A).
 (3) Values shown are a guideline only. Please refer to the unit nameplate



Eurovent certified values

PHYSICAL DATA, 30RBS

30RBS	039	045	050	060	070	080	090	100	120	140	160	
Capacity control	Touch Pilot Junior											
Minimum capacity	%	50	50	50	50	50	50	33	33	33	25	25
Condensers	All-aluminium microchannel heat exchanger (MCHE)											
Fans	Axial Flying Bird IV with rotating shroud											
Quantity		1	1	1	1	1	1	2	2	2	2	2
Maximum total air flow	l/s	3885	3883	3687	3908	5013	5278	6940	6936	7370	10026	10556
Maximum rotation speed	r/s	12	12	12	12	16	16	12	12	12	16	16
Evaporator	Direct expansion, plate heat exchanger											
Water volume	l	2.6	3.0	3.3	4.0	4.8	5.6	8.7	9.9	11.3	12.4	14.7
Without hydraulic module (option)												
Max. water-side operating pressure	kPa	1000	1000	1000	1000	1000	1000	1000	1000	1000	1000	1000
With hydraulic module (option)												
Single or dual pump (as selected)	Pump, Victaulic screen filter, relief valve, expansion tank, purge valves (water + air), pressure sensors											
Expansion tank volume	l	12	12	12	12	12	12	35	35	35	35	35
Expansion tank pressure ⁽⁴⁾	bar	1	1	1	1	1	1	1.5	1.5	1.5	1.5	1.5
Max. water-side operating pressure	kPa	400	400	400	400	400	400	400	400	400	400	400
Water connections with/without hydraulic module	Victaulic											
Diameter	in	2	2	2	2	2	2	2	2	2	2	2
Outside tube diameter	mm	60.3	60.3	60.3	60.3	60.3	60.3	60.3	60.3	60.3	60.3	60.3
Chassis paint colour	Colour code: RAL7035											

(4) When delivered, the standard pre-inflation of the tank is not necessarily the optimal value for the system. To permit changing the water volume, change the inflation pressure to a pressure that is close to the static head of the system. Fill the system with water (purging the air) to a pressure value that is 10 to 20 kPa higher than the pressure in the tank.

ELECTRICAL DATA, 30RBS

30RBS without hydraulic module		039	045	050	060	070	080	090	100	120	140	160
Power circuit												
Nominal power supply	V-ph-Hz	400-3-50										
Voltage range	V	360-440										
Control circuit supply												
24 V via internal transformer												
Maximum start-up current (Un)⁽¹⁾												
Standard unit	A	114	135	143	146	176	213	174	208	248	243	286
Unit with electronic starter option	A	75	87	94	96	114	140	125	150	176	186	215
Unit power factor at maximum capacity⁽²⁾		0.83	0.81	0.81	0.83	0.81	0.78	0.83	0.81	0.79	0.81	0.78
Maximum operating power input⁽²⁾	kW	20	22	25	28	31	36	42	46	53	62	72
Nominal unit operating current draw⁽³⁾	A	26	29	33	36	42	53	55	62	77	85	106
Maximum operating current draw (Un)⁽⁴⁾	A	35	45	47	53	67	73	81	99	108	134	146
Maximum operating current draw (Un-10%)[†]	A	38	49	51	58	75	80	89	110	118	150	159
Customer-side unit power reserve	Customer reserve at the 24 V control power circuit											
Short-circuit stability and protection	See table 9.1											

(1) Maximum instantaneous start-up current at operating limit value (maximum operating current of the smallest compressor(s) + fan current + locked rotor current of the largest compressor).

(2) Power input, at the unit permanent maximum operating conditions (data given on the unit nameplate)

(3) Standardised Eurovent conditions: evaporator entering/leaving water temperature 12°C/7°C, outside air temperature 35°C.

(4) Maximum unit current at 400 V, non permanent operating conditions (values given on the unit nameplate).

† Maximum unit operating current at 360 V, non permanent operating conditions.

Short-circuit stability current (TN system⁽¹⁾)

30RBS	039	045	050	060	070	080
Value without upstream protection						
Short-term current at 1s - I _{cw} - kA rms	3.36	3.36	3.36	3.36	3.36	3.36
Admissible peak current - I _{pk} - kA pk	20	20	20	20	20	15
Value with upstream protection by circuit breaker						
Conditional short-circuit current I _{cc} - kA rms	40	40	40	40	40	40
Schneider circuit breaker - Compact series	NS100H	NS100H	NS100H	NS100H	NS100H	NS100H
Reference No. ⁽²⁾	29670	29670	29670	29670	29670	29670

30RBS	090	100	120	140	160
Value without upstream protection					
Short-term current at 1s - I _{cw} - kA rms	5.62	5.62	5.62	5.62	5.62
Admissible peak current - I _{pk} - kA pk	20	20	15	20	15
Value with upstream protection by circuit breaker					
Conditional short-circuit current I _{cc} - kA rms	40	40	40	30	30
Schneider circuit breaker - Compact series	NS100H	NS160H	NS160H	NS250H	NS250H
Reference No. ⁽²⁾	29670	30670	30670	31671	31671

(1) Earthing system type

(2) If another current limitation protection system is used, its time-current and thermal constraint (I²t) trip characteristics must be at least equivalent to those of the recommended Schneider circuit breaker.

The short-circuit stability current values above are suitable with the TN system.

OPERATING LIMITS, 30RBS

Evaporator water flow rate

30RBS	Flow rate, l/s		
	Minimum	Maximum ⁽¹⁾	Maximum dual pump ⁽²⁾ High pressure ⁽³⁾
039	0.9	3	3.4
045	0.9	3.4	3.8
050	0.9	3.7	4
060	0.9	4.2	4.4
070	1	5	5
080	1.2	5.5	5.2
090	1.3	6.8	6.2
100	1.5	7.7	6.5
120	1.7	8.5	8
140	2	10.6	8.7
160	2.3	11.2	8.9

- (1) Maximum flow rate at a pressure drop of 100 kPa in the plate heat exchanger (unit without hydraulic module).
- (2) Maximum flow rate at an available pressure of 50 kPa (high-pressure module).
- (3) Maximum flow rate with single pump is 2 to 4% higher, depending on the size.

Operating range

30RBS	Minimum	Maximum
Evaporator		
Entering water temperature at start-up	°C	7.5 ⁽¹⁾ 30
Leaving water temperature during operation	°C	5 ⁽²⁾ 20
Entering/leaving water temperature difference	K	3 10
Condenser		
Entering air temperature, full load ⁽³⁾	°C	-10 46
Entering air temperature, part load ⁽³⁾	°C	-10 48
Hydraulic module⁽⁴⁾		
Entering air temperature		
Kit without pump	°C	-20 -
Kit with pump (option 116x)	°C	-10 -
Kit with pump (option 116x) and frost protection option to -20°C (option 42)	°C	-20 -

Note: Do not exceed the maximum operating temperature.

- (1) For entering water temperatures below 7.5°C at start-up, contact Carrier.
- (2) For low-temperature applications, where the leaving water temperature is below 5°C, a frost protection solution must be used.
- (3) Ambient temperature: Please refer to option 20 for low-temperature applications (< -10°C). For transport and storage of the 30RBS units the minimum and maximum allowable temperatures are -20°C and +48°C. It is recommended that these temperatures are used for transport by container.
- (4) Defines the frost-free temperature of the hydraulic components for use without glycol.

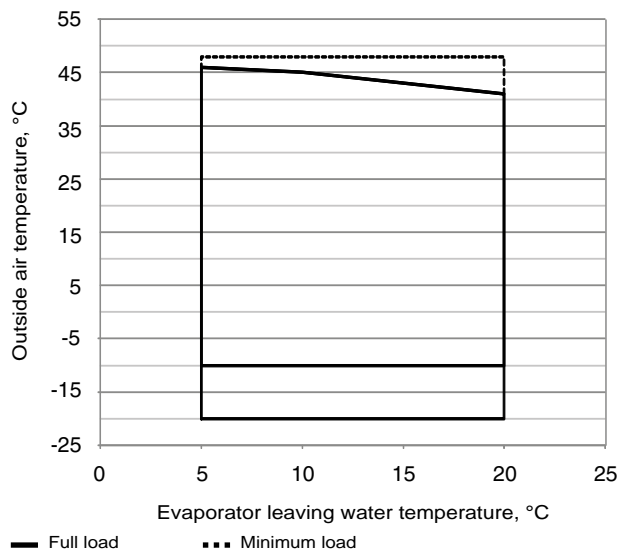

NOTE: This operating range applies up to 130 Pa static pressure without suction air duct for sizes 070 and 080 and 140-160, and up to 240 Pa for all other sizes.



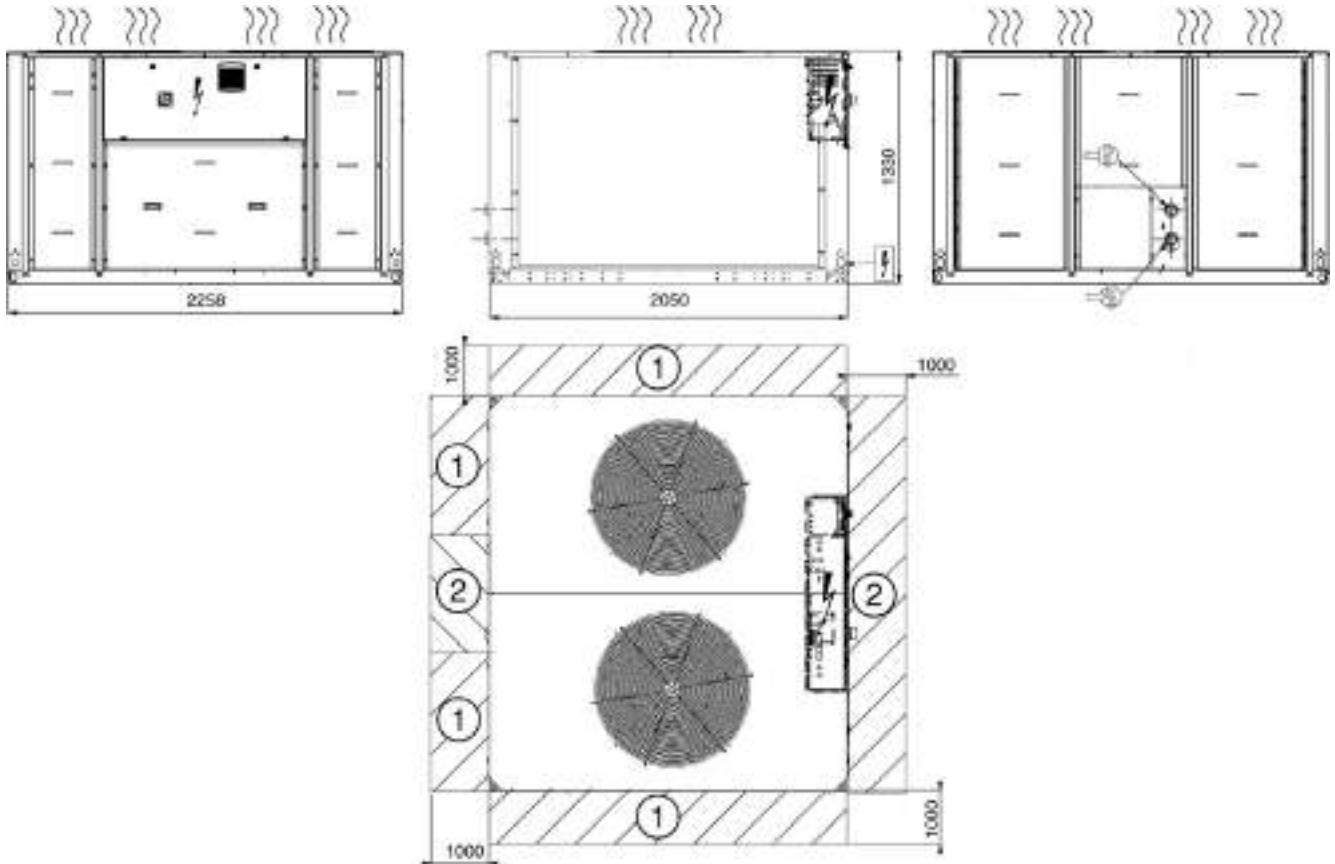

DIMENSIONS/CLEARANCES, 30RBS

30RBS 090-160, units with and without hydraulic module



Legend:

All dimensions are given in mm

-  Control box
-  Water inlet
-  Water outlet
- ① Required clearances for air entry
- ② Recommended space for maintenance
-  Air outlet, do not obstruct
-  Power supply inlet

NOTES:

- A Non-certified drawings.**
Refer to the certified dimensional drawings supplied with the unit or available on request, when designing an installation.
For the location of fixing points, weight distribution and coordinates of the centre of gravity refer to the certified dimensional drawings.
- B In multiple-chiller installations (maximum four units),** the side clearance between the units should be increased from 1000 to 2000 mm.
- C The height of the solid surface must not exceed 2 m.**